

# Quick Open Closures

## Clamp Type

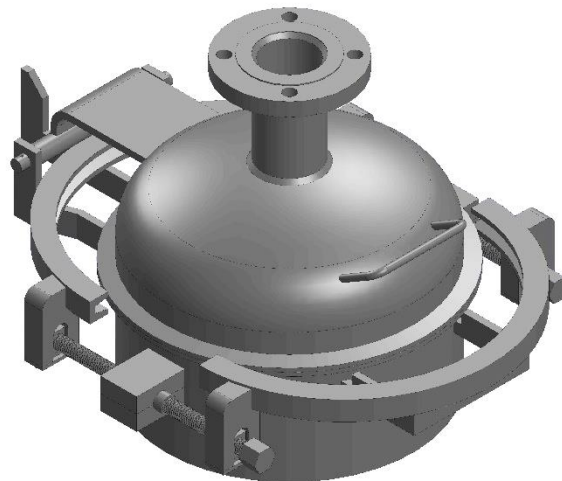
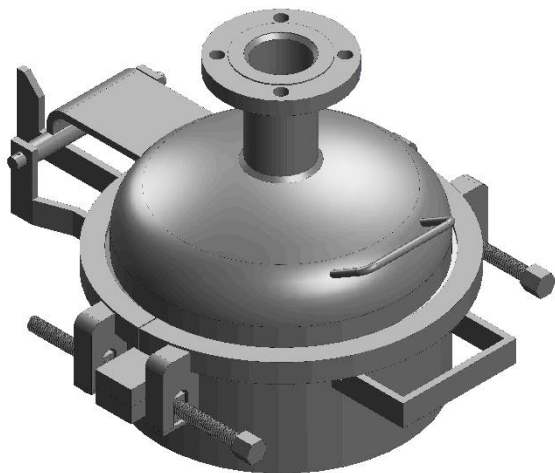

### Salient Features

- Opens in minutes compared to conventional bolted flanged closures
- Requires basic to no tools to operate & maintain
- Closures designed to meet ASME BPVC Section VIII Div. 1
- Finite element analysis software optimized design
- Sizes available from DN300 to DN750
- Pressure ratings available from ASME Class 150 & Class 300
- Fluid service compatible O ring options
- Closures built with Code stamping as option
- Horizontal or vertical configuration

### Applications

- On process vessels like filters, separators, coalescers, strainers
- On pipeline equipment like pig launchers & receivers

### Materials of Construction

- ASTM A350 LF2 / ASTM A516 70N (Hub & Door)
- ASTM A182 F316 / ASTM A240 Typ 316 (Hub & Door)
- Viton O ring
- Other materials of construction on request
- NACE MR 0175 / TM 0824 compliant materials on request

### Industries Used In

- Oil & Gas Production
- Petrochemical Mfg.
- Aviation
- Petroleum Refining
- Environmental
- Marine



**Sungov Engineering Private Limited**  
K27 Ambattur Industrial Estate  
Chennai 600058 Tamilnadu India  
P +91 44 26359940 F +91 44 26501408  
exportsales@sungov.com  
www.sungov.com

**Sungov Asia Pacific Private Limited**  
22 Malacca Street, #04-03  
RB Capital Bldg. Singapore 048980  
P +65 9739 5116 F +65 6826 4204  
sales@sungov.sg  
www.sungov.sg

**Sungov Engineering (M) Sdn. Bhd.**  
Suite 1705A, Level 17, Menara Landmark  
12 Jalan Ngee Heng, 80000 JB Malaysia  
P: +60 12 2898369 F: +60 3 21784313  
sales@sungov.com.my  
www.sungov.com.my