

Duplex Basket Filters - Cast

Solid - Gas, Solid - Liquid Separation

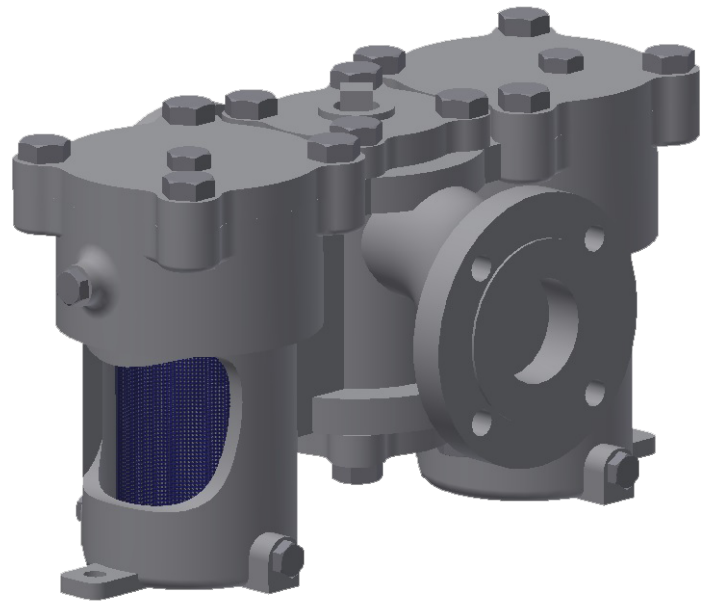
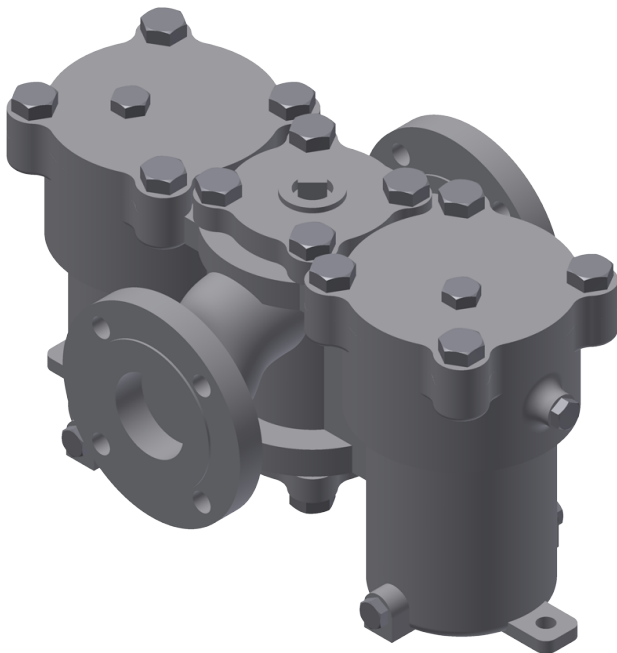

Salient Features

- Compact end to end
- No shutdown time necessary for cleaning
- Online changeover to either filter vessel

Stock Housing Materials of Construction

- ASTM A216 Gr. WCB
- ASTM A351 Gr. CF8
- ASTM A351 Gr. CF8M
- ASTM A351 Gr. CF3
- ASTM A351 Gr. CF3M

Filter Element Materials of Construction

- Austenitic stainless steels
- Austenitic-ferritic stainless steels
- Nickel alloys
- Copper alloys

Design Features

- Gross filter area of 800% inlet cross section area
- Built to ASME B16.34/B31.3 standards
- Inline inlet and outlet nozzles

On-order Housing Materials of Construction

- Other carbon steels
- Other low temperature carbon steels
- Low alloy steels
- Austenitic-ferritic stainless steels
- Nickel alloys

Filter Ratings

- 10 μm to 8000 μm

Size

- Up to 6"

End Connections

- Flanged
- Screwed
- Socket Weld

Pressure Ratings

- Up to ASME #300

Industry Used In

- Oil & Gas
- Power Generation
- Environmental
- Industrial Utilities
- Marine
- Chemicals Manufacturing
- Metals Mining
- Aviation

Duplex Basket Filters - Fabricated

Solid - Gas, Solid - Liquid Separation

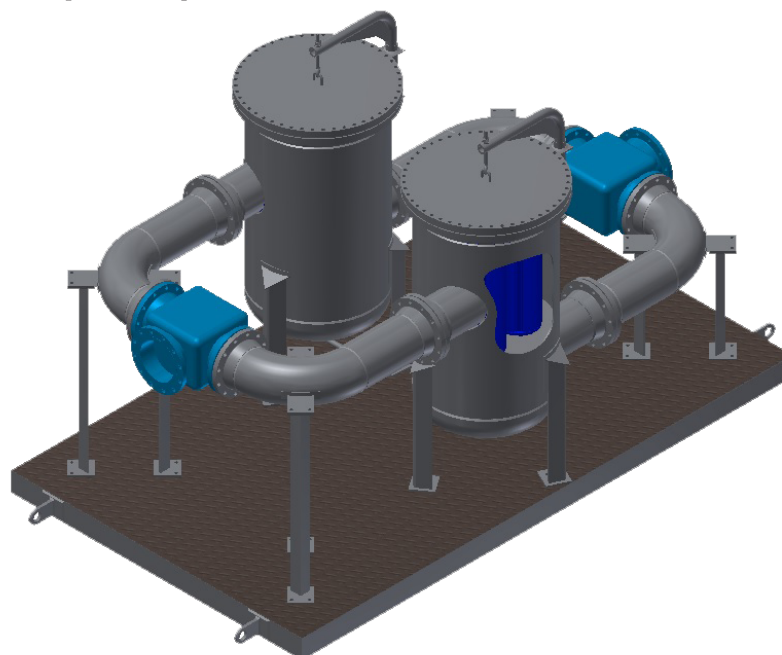

Salient Features

- No shutdown time necessary for cleaning
- Online changeover to either filter vessel
- Dimensional flexibility (fabricated construction)
- Both inline and offline construction available

Stock Housing Materials of Construction

- ASTM A106 Gr. B
- ASTM A105
- ASTM A312 TP304
- ASTM A182 Gr. F304
- ASTM A312 TP316
- ASTM A182 Gr. F316
- ASTM A240 Type 304/316

Filter Element Materials of Construction

- Austenitic stainless steels
- Austenitic-ferritic stainless steels
- Nickel alloys
- Copper alloys

Design Features

- Generous gross filter area for low pressure drop
- Three way or two way isolation valves options
- Built to ASME Sec VIII Div 1/B31.3 standards
- ASME Code stamping as option (filter vessel)

On-order Housing Materials of Construction

- Other Carbon steels
- Other low temperature carbon steels
- Low alloy steels
- Martensitic stainless steels
- Austenitic-ferritic stainless steels
- Nickel alloys
- Copper alloys

Filter Ratings

- 5 μm to 8000 μm

Size

- Up to 24"

End Connections

- Flanged
- Butt Weld

Pressure Ratings

- Up to ASME #2500

Industry Used In

- ◆ Oil & Gas
- ◆ Power Generation
- ◆ Environmental
- ◆ Industrial Utilities
- ◆ Marine
- ◆ Chemicals Manufacturing
- ◆ Metals Mining
- ◆ Aviation



Sungov Engineering Private Limited

K27 Ambattur Industrial Estate
Chennai – 600049, India
P: +91 4426359940 F: +91 4426501408
exportsales@sungov.com | www.sungov.com

Sungov Asia Pacific Private Limited

1, North Bridge Road, #19-04 / 05
High Street Center, Singapore 179094
P: +65 63378091 F: +65 63378094
sales@sungov.sg | www.sungov.sg

Sungov Engineering (M) Sdn. Bhd.

Suite 1705A, Level 17, Menara Landmark
12 Jalan Ngee Heng, 8000 Johor Bahru, Malaysia
P: +60 122898369 F: +60 321784313
sales@sungov.com.my | www.sungov.com.my