

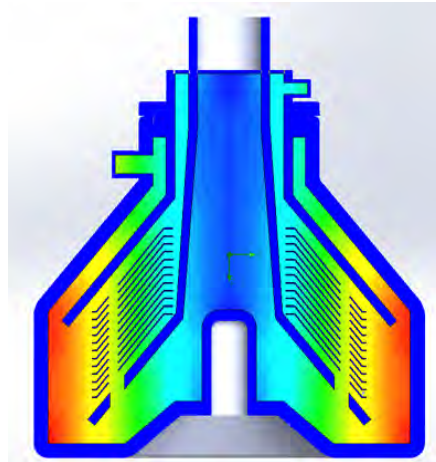

## Solid - Liquid, Solid - Liquid - Liquid Separation



### FUNCTION

Sungov's Centrifugal Separators are precision engineered machines used for separation of solids from liquids as well as solids and liquids from liquids. These high speed rotary devices multiply gravitational effect utilizing centrifugal forces to separate various phases based on differential densities.

#### APPLICATION IN ENVIRONMENT

- Drying of animal slurry
- Drying of Biomass
- Thermal Sludge drying
- Treatment and disposal process of sludge from municipal and industrial waste water

#### APPLICATION IN FOOD & BEVERAGE

- Processing and recovery of dairy and cheese products
- Recycling of related waste materials

#### APPLICATION IN MINERAL FUEL & LUBE OIL

- Purification and conditioning of fuels
- Purification of lube oils
- Treatment & recovery of mineral and fuel oils
- Treatment of slop-oils from refineries and lagoons, slops from lube oils, of bilge water

#### APPLICATION IN FOOD PROCESSING

- Treatment of by-products of fish-processing and meat-processing industries

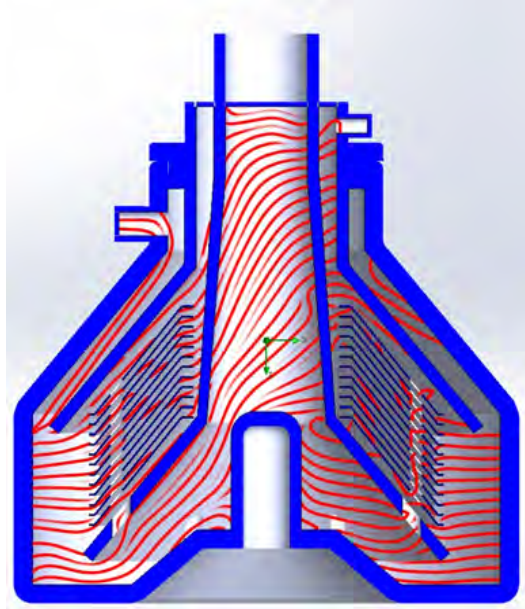

#### APPLICATION IN RECYCLING

- Treatment processes for drilling mud
- Treatment and recovery processes for industrial fluids
- Recycling of polymers and their respective recyclables
- Recycling of service water in industrial processes

#### APPLICATION IN OLEO- CHEMISTRY

- Refining processes for edible vegetable oils, excluding olive oil
- Production process for Oleo-chemistry derivatives

#### APPLICATION IN CHEMICAL PROCESS

- Production process involving intermediate or end products and integrated recycling and recovery processes
- Processes within HDPE, PVC and PP Polymer production
- Production processes for the pharmaceutical and Biotech sector
- Minerals and ores production processes
- Production processes for non-fossil fuels, such as Bio-diesel and Ethanol

### CONTACT US

#### India/Americas/Africa/Europe/Middle East:

Sungov Engineering Private Limited  
160 Baba Nagar Villivakkam Chennai 600049 TN India  
+91 44 26501404 | [exportsales@sungov.com](mailto:exportsales@sungov.com) |  
[domesticsales@sungov.com](mailto:domesticsales@sungov.com) | [www.sungov.com](http://www.sungov.com)

#### Asia Pacific:

Sungov Asia Pacific Private Limited  
22 Malacca Street, RB Capital Building, #04-03 Singapore  
048980  
+65 9739 5116 | [sales@sungov.sg](mailto:sales@sungov.sg) | [www.sungov.sg](http://www.sungov.sg)